

Designed for you.....

We can design and manufacture any design to suit your bespoke needs.

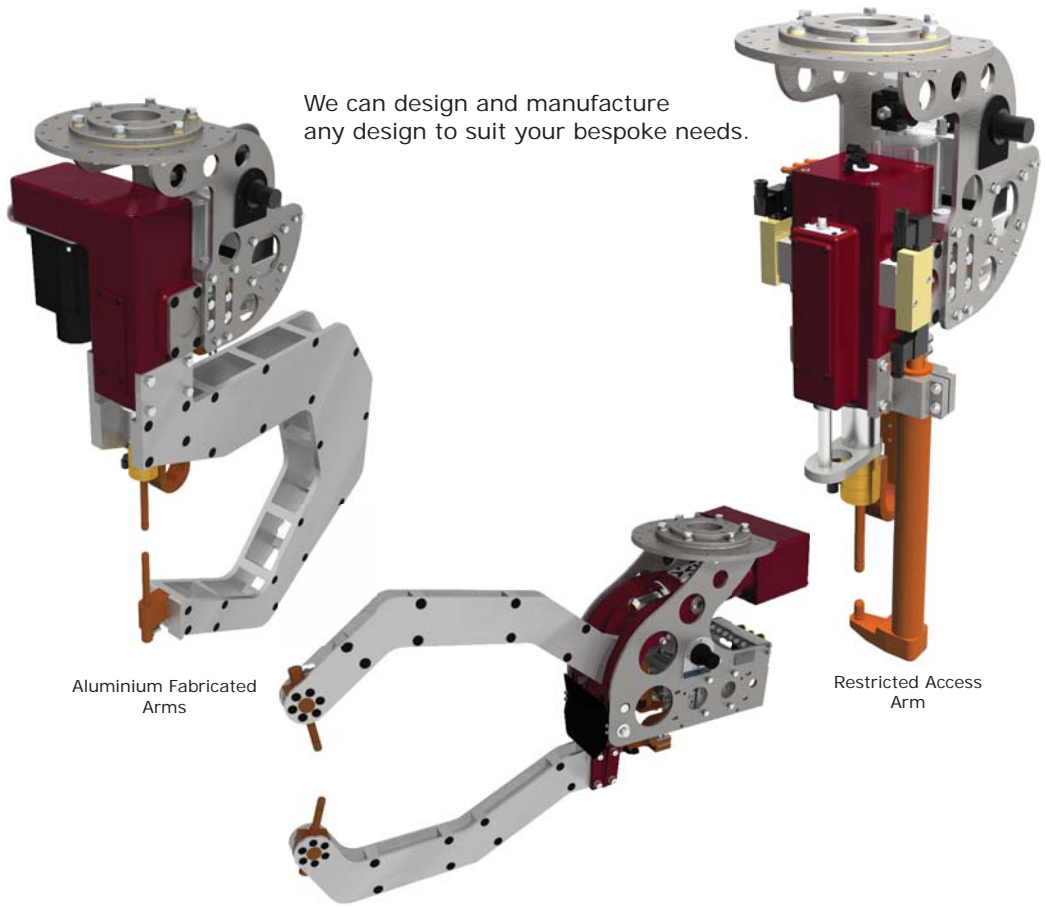

Aluminium Fabricated Arms

Restricted Access Arm

Welding Arms & Adapters



Gun arms are available in various configurations either to our standard design or to the customers specific requirements.

Please contact us for further details

Robot Looms and Dress Packs



C&X Conexion can supply high quality dress packs for all major robot brands.

This allows us to provide a complete solution.

Please contact us for further details

For further information including individual specification data sheets contact



KYRUS Europe GmbH
Föhrenring 3
85413 Hörgerthausen
Germany · Munich Area

Telefon +49 8764 9499173
Telefax +49 8764 948662
E-Mail info@kyrus.eu.com
www.kyrus.eu.com

International



Distributors

www.cx-conexion.com

Specifications correct at time of print, design & specification are subject to change as part of our ongoing development

Designed by users.....



.....Built for industry

The C&X Conexion Welding Gun Range

ARG-C

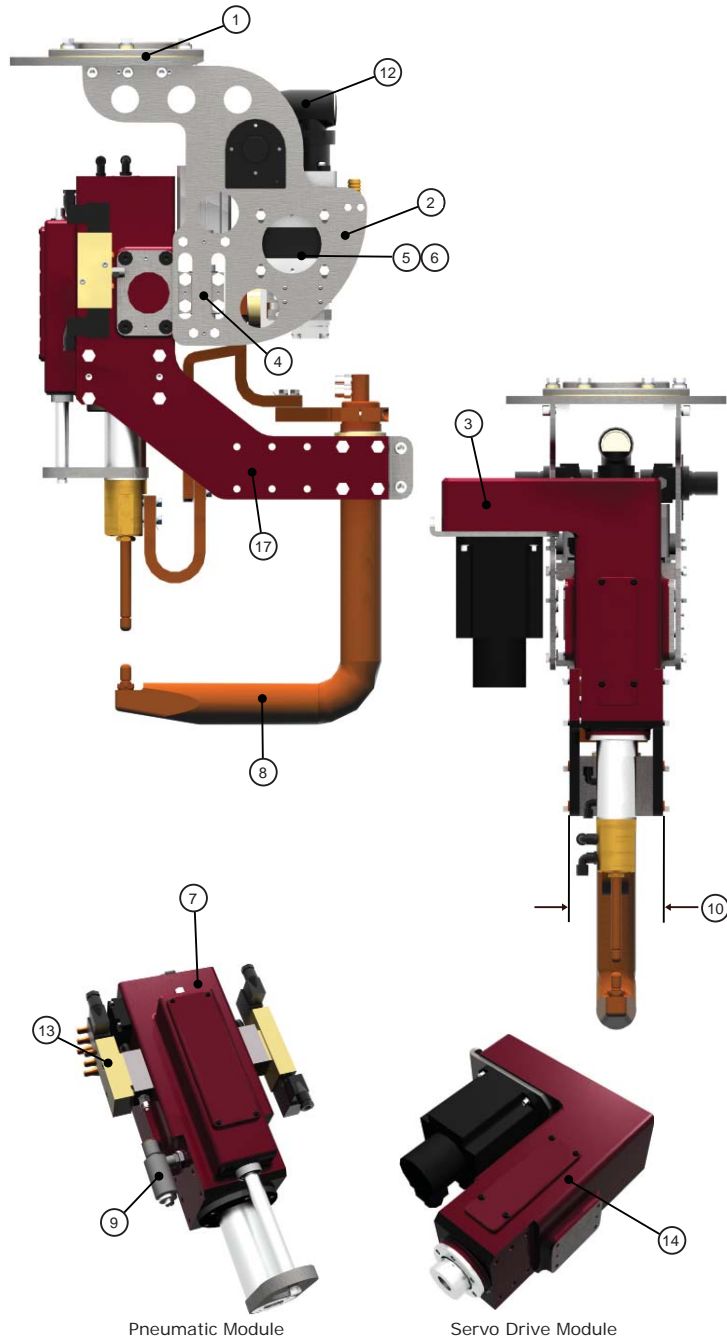

The C&X Conexion welding gun range was developed after working with users all over the world for many years.

C&X Conexion guns are designed to be both practical and cost effective whilst maintaining a robust solution in today's competitive automotive market.

The key advantages of the C&X Conexion guns include:

1. Universal Flange Adaptor, compatible with all major robot brands
2. Simple Plate Design for ease of maintenance.
3. Power Module Options (Servo or Pneumatic).
4. Integrated self equalizing system.
5. Transformer is not a structural part of the gun and hence has no induced stress, and can be replaced easily.
6. Most Major Parts – Single Minute Exchange.
7. Pneumatic guns can be fitted with retract option.
8. Gun arm diameters are standard 50 or 60 mm, other options are available on request.
9. Rapid Exhaust System.
10. Slim Compact Design giving improved gun access to spots.
11. Optional Arm bracing for High Loads. Giving good weld access
12. Multi Contact Connector.
13. SMC Fast operating Pneumatics.
14. Hi Load Ball screw Ram gives reliability (Designed for excess of 20 Million Spots).
15. MFDC transformers are offered as standard, AC are optional.
16. Gun arms can be designed to suit customer requirements.
17. Steel Plate Design for ease of Repair in the Field (Aluminium Available).

ARG-X

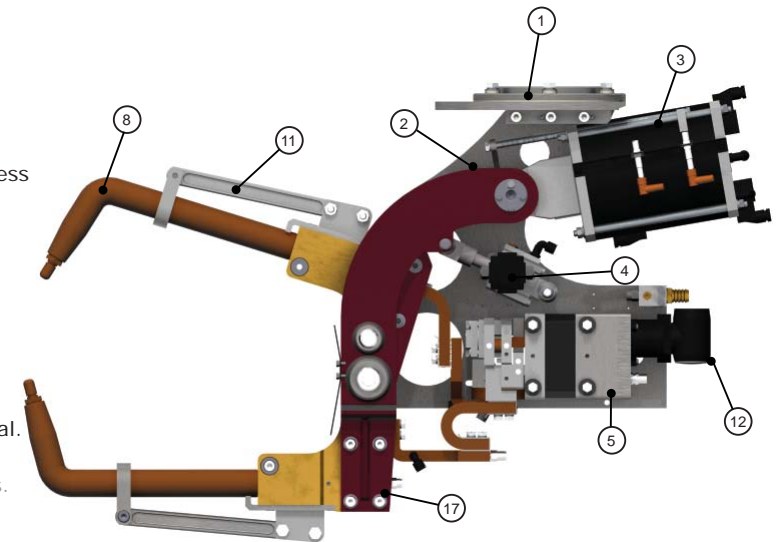
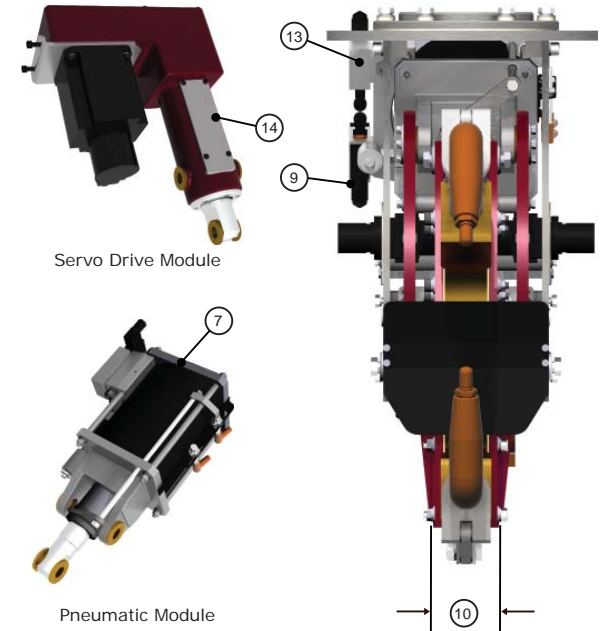

(Side Plate Removed for illustration Purposes Only)